

3-6VFP/DP NEMA 7 & 9  
SOLENOID PILOT  
ENCLOSURE

**GOYEN**

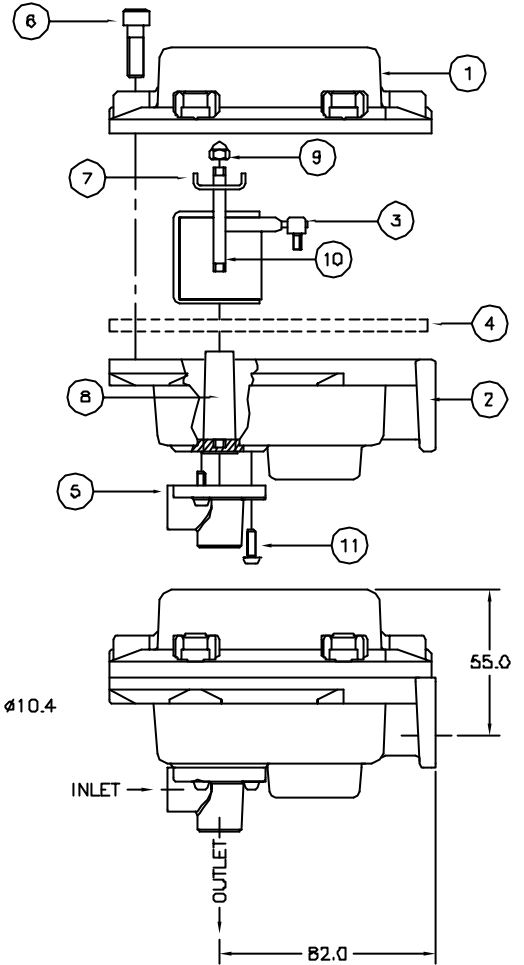
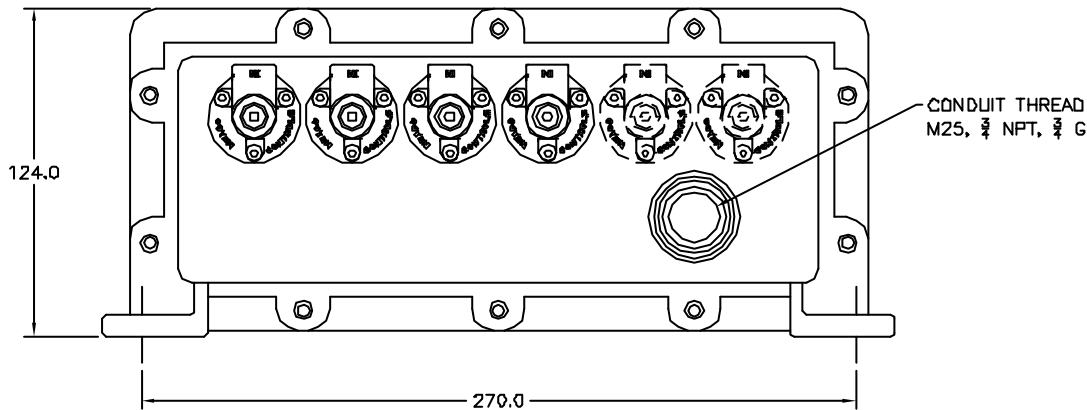
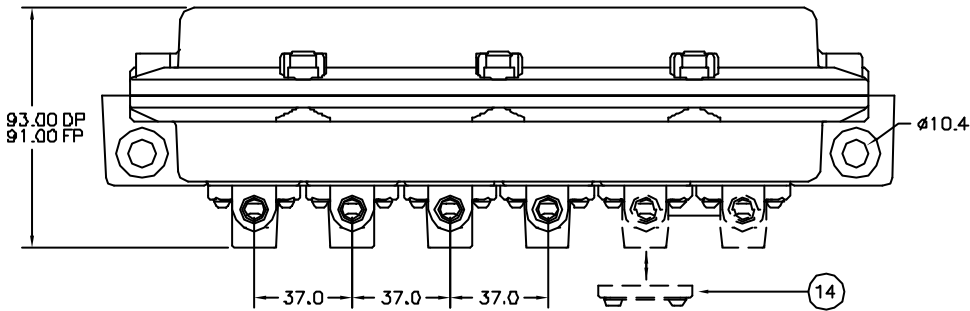
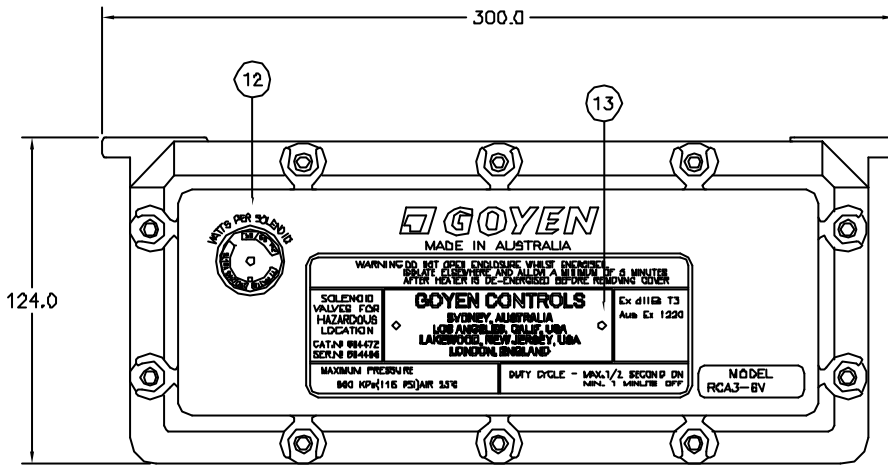

ITEM	DESCRIPTION	STANDARD MATERIAL
1	COVER, FP/DP APPROVED BY SAA, CSA, UL, CENELEC & CE	ALUMINIUM DIECAST
2	6 VALVE BASE, MAXIMUM 6, MINIMUM 4 VALVES MOUNTED, 1 CONDUIT ENTRY	ALUMINIUM DIE CAST
3	QT COILS - FOR VOLTAGE OPTIONS - TBA	
4	SEAL GASKET USED ON D.I.P. - METAL TO METAL SEAL ON F.P.	NEOPRENE
5	1/8 SOLENOID PILOT - RP & NPT INLET/EXHAUST THREADS	
6	M6 x 20 FIXING SCREW	STAINLESS STEEL
7	COIL RETAINING CHANNEL	ALUMINIUM STRIP
8	FERRULE TUBE PRESS FITTED TO ALUM BASE (MUST NOT BE REMOVED UNDER ANY CIRCUMSTANCE)	305 STAINLESS STEEL
9	M5 ACORN NUT - NICKLE PLATED	BRASS NICKLE PLATED
10	M5 COIL SECURIING STUD	MILD STEEL
11	M4 x 10 CAP SCREW	STAINLESS STEEL
12	VOLTAGE PLATE - NOMINATING COIL VOLTAGE INTERNALLY	
13	GOYEN NAMEPLATE / CUSTOMERS NAMEPLATE (OPTION)	CUSTOMER REQUIREMENT
14	PDC BLANKING PLATE USED ON 4 & 5 VALVE ASS'Y. DUST IGNITION PROOF	ALUMINIUM CA313

DOC No	CAS_DG_3-6VFPDP
REVISION No	2
ISSUE DATE	18.7.2002