

Pressure Sensor

PS1000 User Manual

Version 1.1



PS1000 User Manual

Table of Contents

Introduction	4
1.1 System Description.....	4
1.2 How to Use the Manual.....	4
1.3 Certification.....	5
1.4 Unpacking and Inspection.....	5
1.5 Serial Number.....	5
1.6 Warranty Policy.....	6
1.7 Factory Service & Repair.....	6
1.8 Contact Details.....	7
2 Sensor Overview	8
2.1 Theory of Measurement.....	8
2.1.1 Ceramic Capacitive transducers.....	8
2.1.2 Water Density and Gravity.....	8
2.2 Applications.....	9
2.3 Instrument Details.....	9
2.3.1 Sensor Design.....	9
2.4 Cable Details.....	10
2.4.1 Mechanical Specifications.....	10
2.5 Options and Accessories.....	11
2.5.1 Absolute or Gauge.....	11
Closed Venting System (CVS).....	11
2.5.2 Protective Nose Cones.....	12
2.5.3 BSP Fittings.....	12
2.5.4 Cable Options (Inc Detachable Cables).....	12
2.5.5 Serial Breakout Box.....	12
2.5.6 Optional Serial Output – SDI Adapter Unit.....	13
2.6 Sensor Factory Calibration.....	14
3 Sensor Operation	15
3.1 Wiring & Connections.....	15
3.2 Software.....	18
3.2.1 Connect.....	19
3.2.2 Disconnect.....	20
3.2.3 Sensor Setup.....	20
3.2.4 Analogue.....	20
3.2.5 RS232.....	20

3.2.6	<i>Averaging number</i>	20
3.2.7	<i>Advanced Settings</i>	21
3.2.8	<i>Local Gravity</i>	21
3.2.9	<i>Specific Gravity</i>	21
3.2.10	<i>Engineering Units</i>	21
3.2.11	<i>Calibrate Sensor</i>	22
3.2.12	<i>Pressure and Temperature Sensor Readings</i>	22
3.2.13	<i>Load Configuration</i>	22
3.2.14	<i>Save Configuration</i>	22
3.3	<i>Installation</i>	23
3.3.1	<i>Typical Sensor Installations</i>	23
3.3.2	<i>Field Installation must ensure:</i>	23
3.3.3	<i>Cabling Considerations</i>	23
3.3.4	<i>Typical Sensor Installations</i>	23
3.3.5	<i>Other Considerations</i>	24
3.3.6	<i>Guidelines for cleaning equipment</i>	24
4	<i>Appendix A -Additional Information</i>	25
4.1	<i>Specifications</i>	25
4.2	<i>Quick Start Guide – PS1000 Pressure Sensor 4-20mA Output</i>	26
4.3	<i>Quick Start Guide – PS1000 Pressure Sensor Voltage Output</i>	27
4.4	<i>Example Certificate of Conformance</i>	28
4.5	<i>Engineering Note – Detachable Cables</i>	29
4.6	<i>Engineering Note – Closed Vent System</i>	32

Introduction

1.1 System Description

Thank you for purchasing the Greenspan Pressure Sensor Model PS1000. This manual provides a guide to the configuration, operation and maintenance of the PS1000 to provide long term reliable and accurate monitoring.

The Greenspan PS1000 is fully submersible self contained Pressure Measurement Sensor designed for remote applications. It utilises a sophisticated capacitive ceramic pressure sensitive diaphragm. Its special features include high overload protection (up to 60 times nominal pressure) corrosion resistance and long term stability. The changes in the capacitive element varies with applied pressure. This variation is measured by an electronic circuit and converted into an analogue output. The sensor can be supplied in a variety of standard ranges.

The PS1000 has a standard, 2-wire, loop powered, 4-20mAoutput with an option for 0-2.5Vdc suitable for a wide range of Data Loggers, Process Controllers and other third party devices. New features include the ability to re-range the sensor as well as adjust the fluid density and gravity to suit specific applications.

The instrument is packaged in a robust, Acetal housing fully sealed against moisture penetration and is hardwired to either vented or non vented cable supplied by Greenspan.

The sensors are suitable for applications in harsh remote applications including groundwater, streams and rivers, water storage bodies including stratification studies, hydrological run off studies and industrial process monitoring. The sensors are suitable for applications in harsh remote applications including groundwater, salty or acidic water conditions.

1.2 How to Use the Manual

Along with this manual, there are several other documents that may assist in the successful configuration and operation of the Greenspan PS1000 Sensor. These should be maintained on file as a permanent reference as to the features, applications and use of the PS1000.

Greenspan PS1000 – Specifications Brochure

Greenspan PS1000 – Certificate of Conformance

Greenspan PS1000 – Quick Start Guide

1.3 Certification

The PS1000 sensors are assembled and tested in accordance with Greenspan's ISO 9001 Quality Certified System. Following calibration the sensors undergo a range of additional control processes to ensure that all specifications are consistent and documented.

- ***The instrument is visually inspected, marked and labelled.***
- ***The complete sensor calibration record is archived for reference, and batch number information is kept on file for statistical analysis.***
- ***An individual Certificate of Conformance is issued to the customer.***

1.4 Unpacking and Inspection

All Greenspan Analytical Sensors are made to order and are individually calibrated and inspected. This ensures that they leave the factory in a working condition. They are packed in new cartons for shipping. On receipt, the customer should inspect the packaging and contents for any signs of damage during transportation. The customer should also check that all items on the delivery note have been received.

Please contact the factory in case anything has been damaged or missing. A full set of documentation including Certificate of Conformance, Quick Start Guide, and Full Operator Manual will be provided with all equipment – either in hard copy format or in electronic format on the CD shipped with the goods.

The Sensor is fitted with an Acetal body which provides superior corrosion protection in a wide range of chemically active waters. Because an individual sensor may be used in a variety of locations, media compatibility should be checked before installing and advice sought from Greenspan if any doubt exists.

1.5 Serial Number

Checking the Model Number and Range

Before installing your Greenspan PS1000 sensor check the information on the label is correct to confirm you have received the instrument you have ordered. The label will look similar to this.

MODEL	PS1000
RANGE	0 – xx m
S/N	012345

The customer is advised to keep a record of the serial numbers in case the sensor is lost or the label damage. Greenspan Analytical keeps records of all sensors sold including a calibration history.

1.6 Warranty Policy

Greenspan Analytical warrants all new Greenspan products against defects in materials and workmanship for **12 months** from the date of invoice.

Products that prove to be defective during the warranty period will be repaired or replaced at the discretion of Greenspan Analytical.

Under Greenspan Analytical warranty conditions; it is the responsibility of the customer to cover shipping charges back to the factory. Upon repair/replacement Greenspan Analytical will cover the return shipping charges to the customer.

This warranty does not apply to products or parts thereof which have been altered or repaired outside of the Greenspan Analytical factory or other authorised service centre; or products damaged by improper installation or application, or subjected to misuse, abuse neglect or accident. This warranty also excludes items such as reference electrodes and Dissolved Oxygen membranes that may degrade during normal use.

Greenspan Analytical will not be liable for any incidental or consequential damage or expense incurred by the user due to partial or incomplete operability of its products for any reason whatsoever or due to inaccurate information generated by its products.

All Warranty service will be completed as soon possible. If delays are unavoidable customers will be contacted immediately.

Any sensor should not be dismantled unless under instruction from Greenspan Analytical Technical Service staff. Incorrect handling will void the warranty.

1.7 Factory Service & Repair

The correct choice of sensor and assistance with field installation can be provided by Greenspan and their sales offices. A correct choice of equipment, together with technical advice and field experience should result in long term success in the field. **Greenspan Technical Services** is dedicated to customer support and provides assistance in the selection, installation, deployment and commissioning of sensors with a full range of consulting services. All Greenspan products are designed, developed and manufactured in Australia and can be supplied at short notice.

If for some reason sensors are required to be returned to our factory or your sales representative, please note the model and serial number, Describe the problem, including how and under what conditions the instrument was being used at the time of malfunction. Clean the product and cable. Decontaminate thoroughly if used in toxic or hazardous environment. Carefully pack product in original packaging if possible & include a statement certifying product and cable have been decontaminated with supporting information. Products returned for repair must be accompanied by a completed GRA (Goods Return Advice) form. All sensors returned for service and repair work must be properly decontaminated prior to return. A cleaning charge may be applied to sensors that require further decontamination. Service work will not commence until the quotation has been accepted by the customer. A purchase order for all repair and service work will be required before work is carried out.

1.8 Contact Details

Australia

Head Office
Goyen Controls Co Pty Ltd
268 Milperra Road
Milperra, NSW 2214

Telephone: 1800 805 372
Facsimile: 1300 658 799

Sales and Service

**Queensland, South Australia
Victoria, Western Australia**

Telephone: 1800 805 372
Facsimile: 1300 658 799

USA

Goyen Valve Corporation
1195 Airport Road
Lakewood
New Jersey 08701, USA

Telephone: 1 732 364 7800
Facsimile: 1 732 364 1356

Asia

Goyen Controls Co Pty Ltd
Shanghai Representative Office
1209 Greenland Business Centre
1258 Yu Yuan Road
Shanghai PC200050, CHINA

Telephone: 86 21 5239 8810
Facsimile: 86 21 5239 8812

Goyen Controls Co Pty Ltd
73-M Jalan Mega Mendung
Kompleks Bandar OUG
58200 Kuala Lumpur, MALAYSIA

Telephone: 60 37 987 6839
Facsimile: 60 37 987 7839

Greenspan Singapore Pte Ltd
02-01, Minwa Industrial Building
39 Genting Lane
Singapore 349554

Telephone: 65 6748 0140
Facsimile: 65 6748 2534

Europe

Goyen Controls Co UK Ltd
Unit 3B Beechwood
Chineham Business Park
Basingstoke, Hampshire, RG24 8WA
UNITED KINGDOM

Telephone: 44 1256 817 800
Facsimile: 44 1256 843 164

Tyco Umwelttechnik GmbH
Im Petersfeld 6
D-65624 Altdenz
GERMANY

Telephone: 49 6432 1001/1002
Facsimile: 49 6432 63810

Mecair S.r.l.
Via per Cinisello 97
20054 Nova Milanese
Milano,
ITALY

Telephone: 39 362 375 118
Facsimile: 39 362 375 124

Address: *Tyco Environmental Systems
Greenspan Analytical Manufacturing Plant
22 Palmerin Street
WARWICK QLD 4370
AUSTRALIA*

Phone: + 61 (0)7 46601888
Fax: + 61 (0)7 46601800

Internet: www.tyco-environmental.com

2 Sensor Overview

2.1 Theory of Measurement

The PS1000 Pressure Sensor utilizes a ceramic-based, capacitive element as the transducer. This is designed to be of rugged construction and incorporates active electronics as an integral part of the transducer substrate to enhance reliability and accuracy. Force applied to the ceramic element, due to the pressure, deforms its shape. This deformation causes a change in capacitance which can be measured by the electronics. The inherently stability and toughness of the ceramic ensures the repeatability and long term accuracy of the readings are maintained under the harshest field conditions.

The onboard microprocessor converts the transducer output voltage to a digital signal and also measures the transducer temperature. This information is used to temperature compensate the sensor over the range 0 - 50°C. The result is converted to an analogue output of typically 4-20mA.

2.1.1 Ceramic Capacitive transducers

Benefits of the Ceramic Capacitance Sensors over other types of sensors are:

- Extremely high overload limit (typically up to 10 X overload protection)
- Absolute resistant to wear
- High temperature stability
- Excellent Long term stability
- Excellent Repeatability and linearity
- No hysteresis effects normally associated with Strain Type Sensors
- Corrosion resistant – Other sensors require contact of stainless steel face
- Not subject to mechanical fatigue that may affect strain gauge type sensors
- Low power consumption suitable for remote monitoring & control units

2.1.2 Water Density and Gravity

When pressure sensors are used for depth readings of any fluid the density becomes an important parameter. In Australia a standard describes the relationship between force and water depth:

Australian Standard AS1376-1973 *

1kPa = 102.15 mm of pure water. @20degC

There is typically a 3% difference in the density between pure water and seawater. This difference should be considered when particular measurement accuracy's are required.

Another factor affecting calibration accuracy is gravity. The departure from standard gravity in Warwick, Qld is -0.17%. at latitude 27.973 deg, height 458m above sea level.

All Greenspan sensors are corrected for gravity as part of their calibration.

*For conditions, see Clause 1.3.8.3 Australian Standard AS1376

2.2 Applications

Applications in which the Greenspan PS1000 can be used include:

- Monitoring of streams and rivers.
- Monitoring of water storage bodies including stratification studies.
- Hydrological run off studies.
- Ground and bore water analysis.
- Industrial process monitoring.

2.3 Instrument Details

2.3.1 Sensor Design

The Greenspan PS1000 consists of the following primary elements:

- Ceramic capacitance transducer with ¼" BSP thread
- Stainless steel or acetal body material
- Moulded cable entry

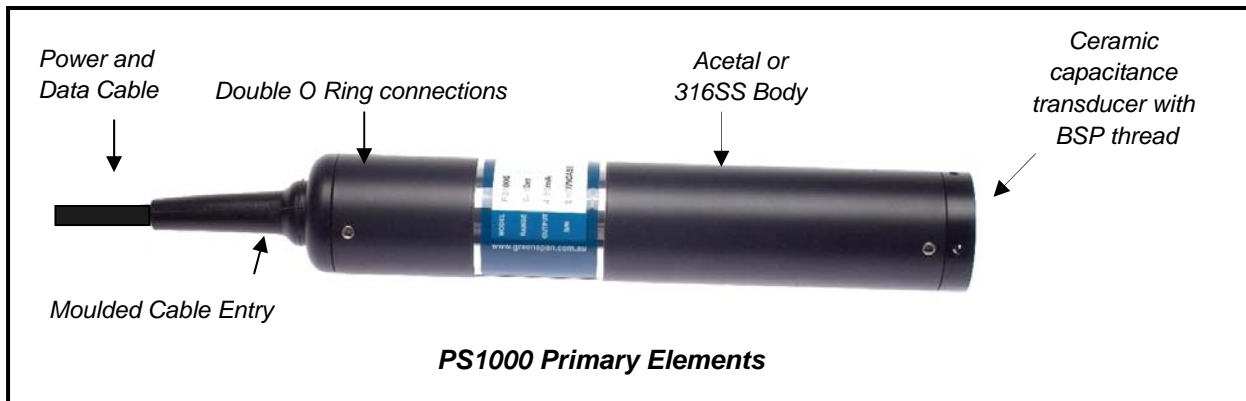

2.4 Cable Details

All Greenspan Sensors utilise a specially designed Polyurethane Cable. The cable contains 12 x conductors, 1 x drain wire, and an internal vent tube. The outer jacket is made from UV stabilized Polyurethane and is suitable for all external, underwater or harsh environment applications. This common cable construction is utilized for vented and non vented sensors and all Greenspan Water Quality Sensors. Cables are generally factory fitted at time of manufacture in specified lengths. Cables can be joined or repaired in the field providing a waterproof connection can be maintained. Alternatively, cables can be terminated in waterproof junction boxes where cabling to other devices or longer cable runs are required.

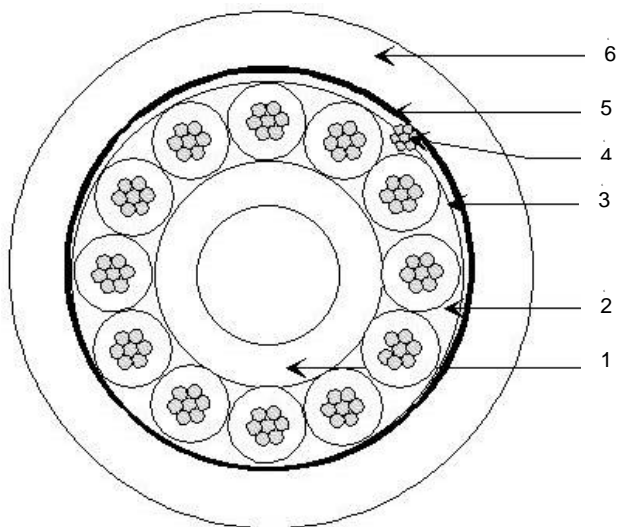

Cable Construction

- 1 – **Vent Tube:** Polyamide
(size ID x OD) 2.40 x 3.20 mm
- 2 - **12 x Conductors**
7 x 0.20 mm Tinned Copper
Section = 0.22mm² AWG24
Insulation: Polypropylene
(size) = 1.10 mm ± 0.05 mm
- 3 - **Tape:** Polyester
- 4 – **Drain Wire:** 7x0.20 TinCu
- 5 - **Tape:** Polyester Aluminium
- 6 - **Jacket:** Polyurethane black,
(size OD) 8.05 mm ± 0.15

2.4.1 Mechanical Specifications

- Specially Manufactured Greenspan Cable with 12 cores and Internal Vent
- High chemical resilience and abrasive resistance
- Conductor cross section : AWG 24,
- Electrical Resistance 9 ohm per 100m (per conductor)
- Operating temperature: 85°C (max.),
- Bending radius (static) : 6 ,
- Bending radius (dynamic) 12.
- Max Operating voltage : 250V
- Jacket Printing (white colour each meter)
- Conductor colour codes : green, yellow, white, black, brown, turquoise, violet, pink, red, blue, grey
- Tensile Strength is sufficient to self suspend the Greenspan Sensor to depths of 300m.
- Long term creep due to temperature effects or tensile loading is negligible.

The moulded cable is fitted to the sensor using a double o ring seal and located using 2 x grub screws. The length of the cable is not critical to the long term calibration and operation of the sensor (provided the electrical requirements such as minimum supply voltage are maintained).

2.5 Options and Accessories

2.5.1 Absolute or Gauge

Gauge Sensors are vented to atmosphere so that the effects of changes in barometric or atmospheric pressure do not affect water level readings. Sensors that are not vented to atmosphere are referred to as Absolute Sensors. The primary difference between the two types of sensors is the effect of atmospheric pressure on the water level measurements they provide.

Barometric Pressure acts on both sides of a Gauge sensor (ie via the water on one side and via the vent tube on the other). The Barometric pressure is cancelled out and has no effect on the water level readings. Gauge Sensors will read zero in air.

Barometric atmospheric pressure acts only on one side of a non vented or Absolute Sensor (on the water side). Any changes in Atmospheric pressure will be detected by the sensor and measured as changes in water pressure. As the Barometric pressure varies, these changes will be measured as water level changes even though the actual water level may have remained steady. Typical variations in Barometric Pressure when converted to head of water are in the order of +/- 100mm. A large change in Weather Pattern (Storm Front) may cause a drop in Barometric Pressure by up to 20Hpa which would cause an error of 200mm. Water level variations caused by Barometric Pressure can be removed by monitoring barometric pressure (eg via a weather station or barometric sensor) and then post processing the absolute water level readings.

The lowest, standard range, absolute pressure sensor offered is 20m, which is suitable for measuring water levels of up to approximately 10m. Absolute sensors will read zero in a perfect vacuum and around 10m in air depending on the atmospheric pressure.

Gauge sensors are suitable for most monitoring applications where water level readings are required. Absolute sensors are suitable for applications where a vented cable is not desirable (eg. Battery pack only sensors).

Closed Venting System (CVS)

When pressure sensors are deployed, there can be a difference between the atmospheric temperature and the temperature of the sensor at depth.



7CVS-001 Closed Vent System

This temperature differential causes a pumping effect to occur whereby moist air from the surface is drawn into the sensor through the vent line. This moisture can condense on sensitive electronic components due to warm surface air cooling inside the sensor.

Sealing the system against exposure to the atmosphere and conditioning the existing air in the vent tube can alleviate this problem. Silica desiccant crystals easily absorb moisture thereby drying the air and are used in the closed loop venting system **7CVS-001**.

For all gauge (vented sensors) a Closed Vent System must also be fitted (pictured left). A single 7CVS-001 is designed to handle sensor cable lengths up to **70 metres**. Multiple units may be joined together for greater capacity. Please refer to the Engineering Note in the appendix section on the manual for detailed instructions on the installation of the 7CVS-001.

Dimensions (including filter): length x width x height 16cm x 7cm x 5cm.



2.5.2 Protective Nose Cones

A protective copper nose cone (*Greenspan Part # 492-0241*) can be fitted to the pressure transducer to inhibit biological or marine growth on the sensor face. Similarly Greenspan also offer a stainless steel nose cone (pictured left, *Greenspan Part # 492-0246*)



2.5.3 BSP Fittings

Brass BSP threaded adaptors (*Greenspan Part # 492-0238*) can also be fitted to the PS1000 for connection when monitoring pressure in process applications. (Such applications may include, pipeline monitoring, gas bubblers and tanks).

2.5.4 Cable Options (Inc Detachable Cables)

A standard sensor is supplied with a fixed moulded cable entry and bare wire connection. An optional detachable cable is available. The detachable cables have a 7 pin Hirschman connector at the end of the cable opposite to the sensor.

Detachable cables are available in a range of standard lengths and are interchangeable amongst the range of Greenspan sensors. This option can provide benefits and cost savings.

Please refer to the [Engineering Note](#) in the appendix section of the manual for detailed instructions on connecting and disconnecting the detachable cable.

2.5.5 Serial Breakout Box



7BB-1000 Serial Breakout Box

The serial breakout box (*Greenspan Part # 7BB-1000*) allows connection between the PS1000 and a sensor and PC. The user is able to communicate with the sensor in RS232 mode to perform user field adjustments and calibration via the PS7000 Utility Software (supplied on CD with all PS1000's purchases).

The serial breakout box can also be connected directly to a multimeter, enabling the user to check the analogue inputs on the sensor. The 7BB-1000 is supplied with a serial communications cable (*Greenspan Part # 087-0088*). Please refer to the Engineering Note in the appendix section of the manual for information.

2.5.6 Optional Serial Output – SDI Adapter Unit

A feature of the sensor is the ability to also provide serial output in SDI12 format using a small SDI Adapter unit connected to the end of the sensor cable. The SDI12 Adapter unit (*Greenspan Part # 7SDI-1000*) provides a standard 3 wire SDI12 output for connection to a third party Data Logger or Process Controller.

Please refer to the 7SDI-1000 User Manual for more comprehensive instructions on its use. The following information briefly outlines the quick set-up steps for both the sensor and 7SDI-1000.

Quick Set Up

Sensor set up

Set the PS1000 as a RS232 instrument

1. Connect the sensor to a PC and run the PS7000 utility.
2. Click Sensor Set Up
3. Click RS232 radio button
4. Click OK

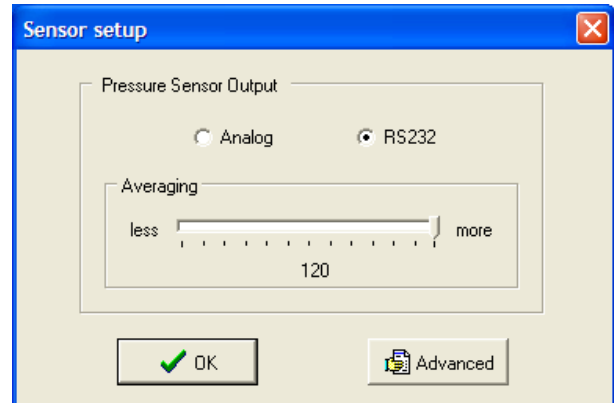

Provide physical connections

There is a cable available to assist connecting a bare wire sensor to the 7SDI-1000 adapter. Greenspan Part # 5CC-770 (pictured below)



Plug the Hirschman connector into the mating connector on the 7SDI-1000

Use the screw terminals to join the bare wires from the sensor. Red to Red, Blue to Blue, Yellow to yellow and Violet to Violet.

7SDI-1000

Set the 7SDI-1000 for the PS1000/7000

2.6 Sensor Factory Calibration

The sensor is assembled and calibrated to the required range using Ruska Digital Pressure controllers which are externally calibrated in NATA certified laboratories.

- The sensor is calibrated at multiple points over its pressure and temperature range (typically 36 points).
 - The calibration is validated at multiple different points (typically 25 points).
 - Accuracy and linearity is calculated from the validation data.
- An extensive range of final calibration and inspection tests are carried out on every sensor.
- The sensor is visually inspected and packed, ready for despatch.
- The complete calibration records, sensor history and batch number are placed on file and archived.

3 Sensor Operation

3.1 Wiring & Connections

The PS1000 is a 2 wire, loop powered 4-20mA output sensor with an option for 0-2.5Vdc. It is normally powered by a 8-30V DC power supply – which can be battery, solar or Mains Plug Pack.

The following diagram illustrates the typical wiring arrangement for the PS1000 with 4-20mA output.

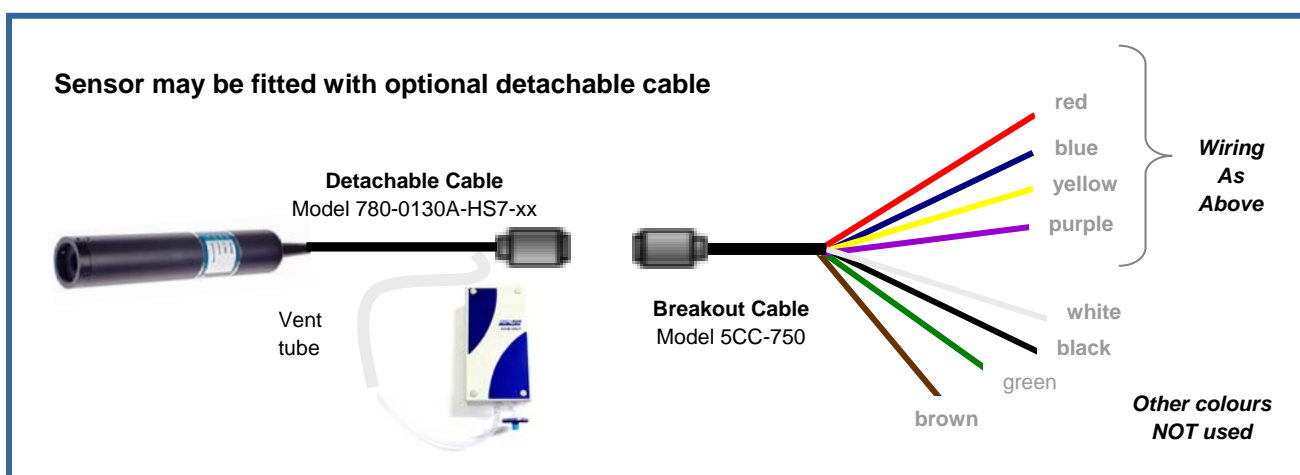
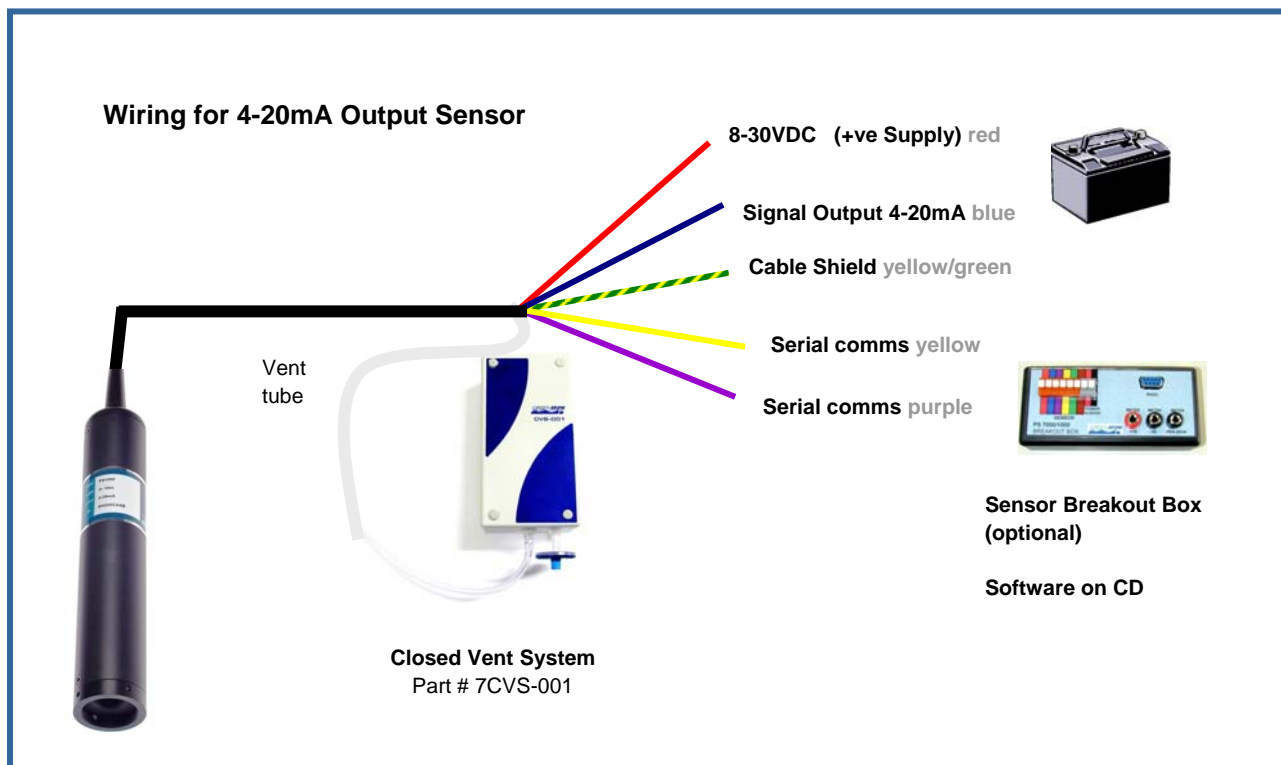

The following diagram illustrates the typical wiring arrangement for the PS1000 with VOLTAGE output.

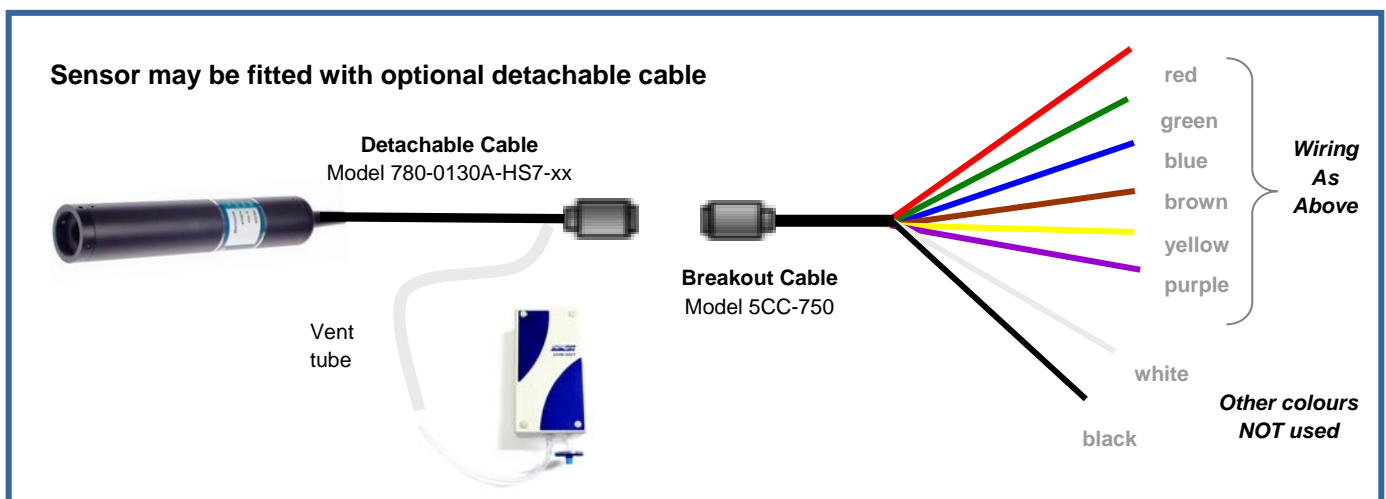
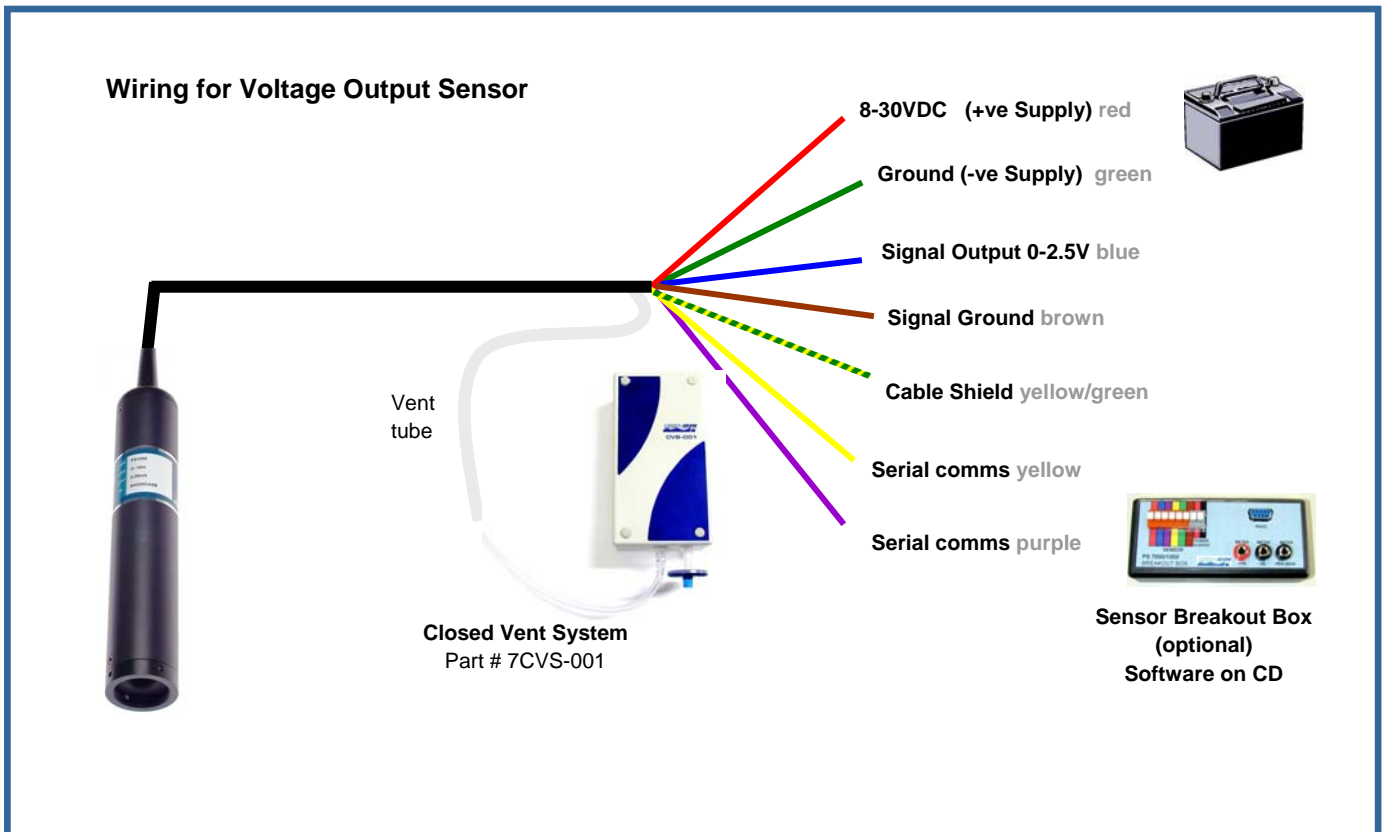

Alternatively the PS1000 Sensor can be used as an SDI12 Sensor using the optional Greenspan SDI12 Adaptor.

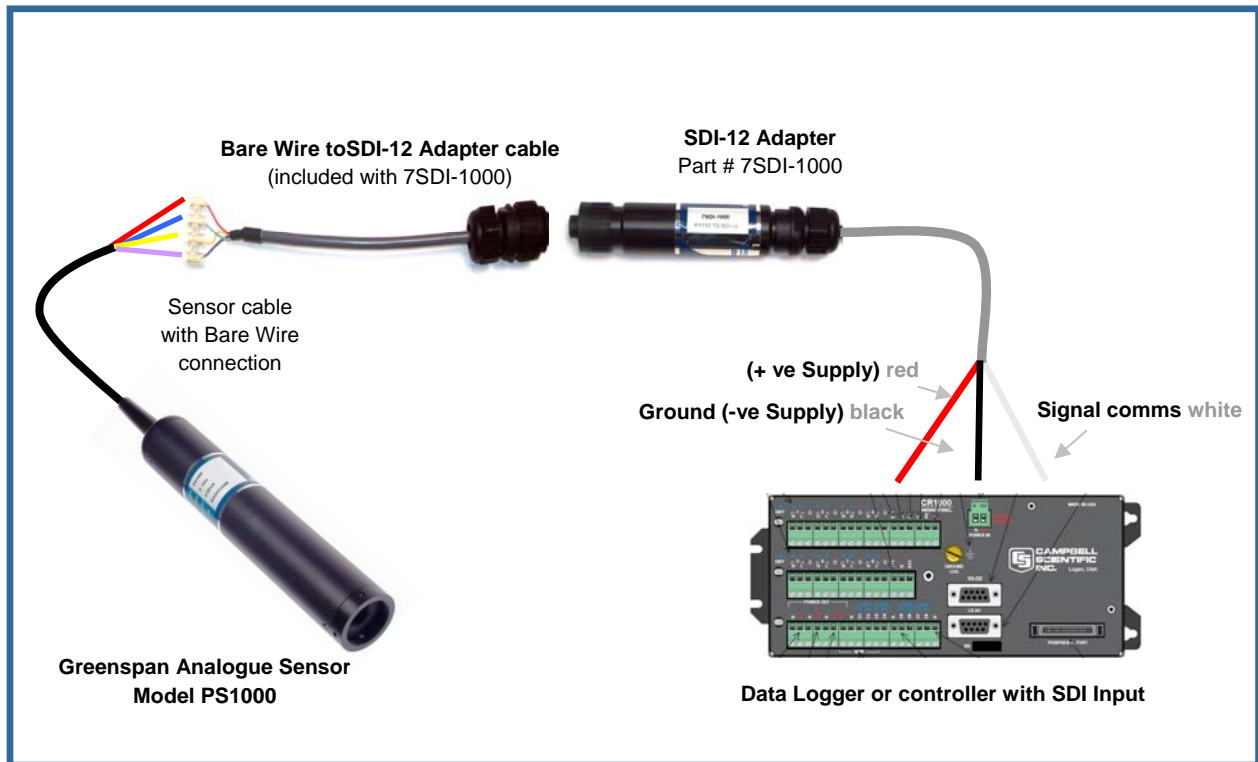

Typically the sensor will be connected to a Data Logger or Process Controller which will provide the power and ground connections and provide connections for serial SDI12 output.

The Power requirements of the sensor are detailed in the Specifications Brochure.

3.2 Software

Communication with the PS1000 Sensor is performed through the PC's RS232 serial port via the 7BB-1000 serial breakout box and supplied software: **PS7000 Utility** (*PS7000 Utility is supplied free of charge on all PS1000 orders Greenspan Part # 7CD-1000/7000*)

To use the full functions of the software a fully operational sensor with power supply and all communications leads should be available.

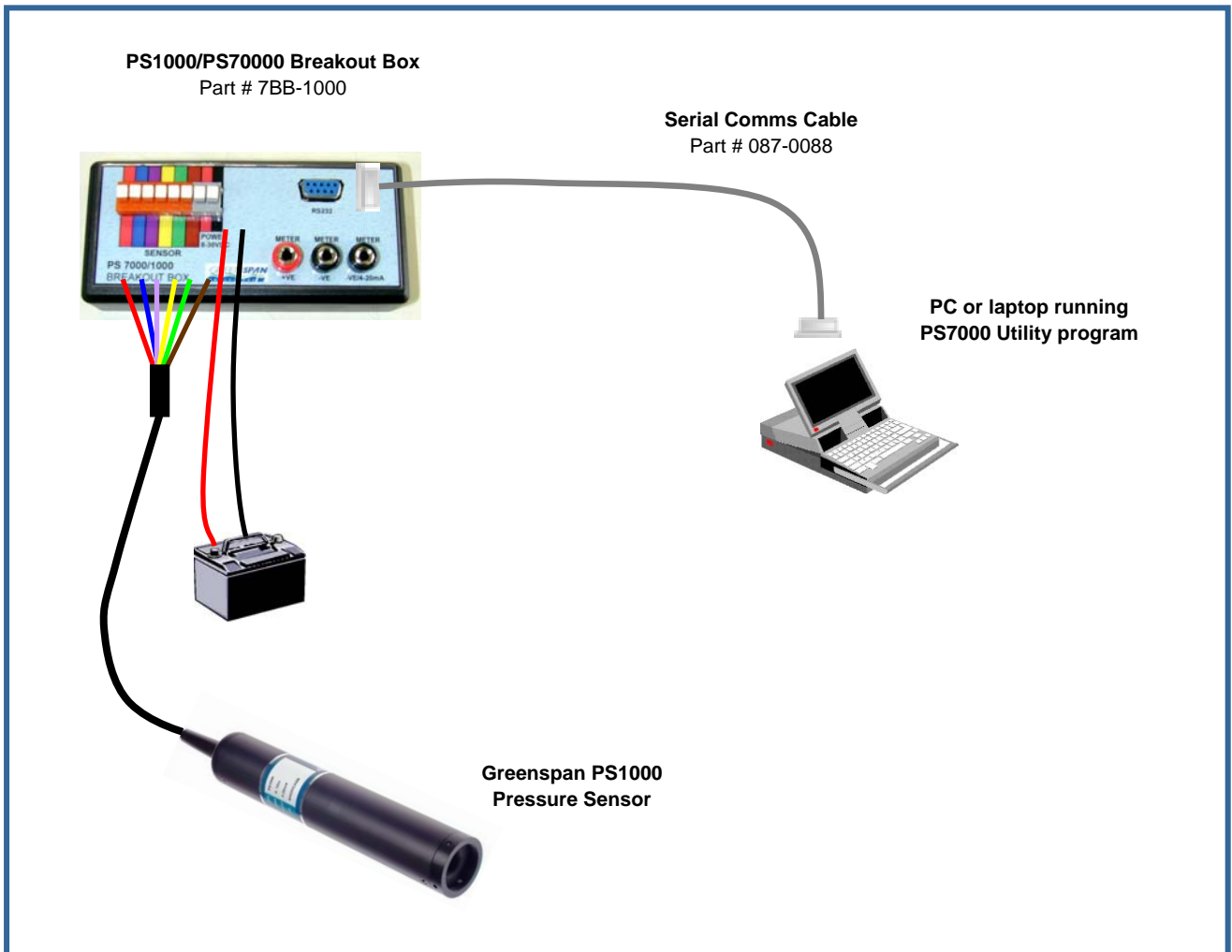

To Load the Software, Place Software CD in drive, and open the Application (exe) file.



The main screen is divided into three sections.

The top panel consists of a drop-down-list of all available serial ports, a Connect button to connect to / disconnect from the sensor and a Help button to access the online help. These are the only active controls at start-up, select the port number where a sensor is connected, ensure that power supply is turned on then click Connect to initiate communications.

The middle section contains three more buttons: Load Configuration, Save Configuration and Sensor Setup; use these buttons to load sensor settings from a file, to save the current settings to a file or to access the sensor configuration screens. These controls remain disabled until a connection is established. To the right of these buttons are two text fields which display the sensor's serial number and firmware revision, if one is connected.

There is a data panel which displays current readings for both Pressure and Temperature; but only visible when RS232 is selected as sensor output.

A status bar at the bottom shows the current state of the interface, while the LEDs indicate activities on transmit and receive lines.

3.2.1 Connect

At start-up, the only active controls are a drop-down-list of all available serial ports and the Connect button. Select the port number where a sensor is connected, ensure that power supply to the sensor is turned on then click Connect to initiate communications. The program will first read the sensor's serial number, its status and then the entire configuration data file.

All other program controls remain inactive until a connection is established. Once connected, the COM port control will be greyed out and disabled while the 'Connect' button is changed to 'Disconnect' which can be used to terminate the current session.

Data transfer typically takes around 10 seconds to complete. It may take longer if there are errors occurred during data transfer; the interface will retry up to three times before reporting an error message.

In the event when the sensor's serial number has been read but the interface fails to receive a valid configuration due to corrupted data, the user can upload new configurations to the sensor from a file stored on PC, provided that the file's serial number matches up with that of the sensor.

3.2.2 Disconnect

Click Disconnect to terminate communications with the currently connected sensor.

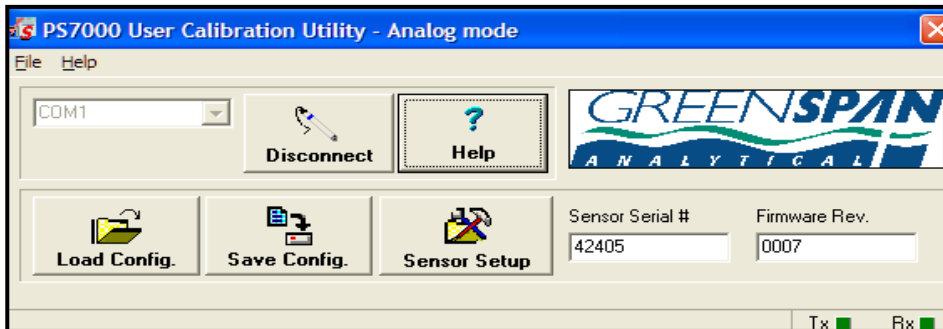

3.2.3 Sensor Setup

The Sensor Setup screen allows the user to select between analogue or serial output; it also lets the user adjust the number of averaging points. Click Advanced button to access more configuration items and to re-calibrate sensor.

3.2.4 Analogue

Depending on the default factory setup, the sensed pressure is output as 4-20mA signal or 0-2.5V signal

3.2.5 RS232

The sensed pressure is output as digital data and displayed on screen, together with current temperature.

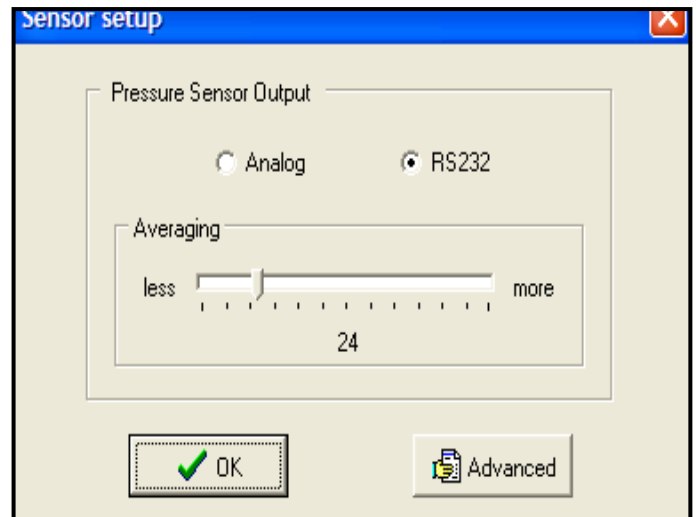

Note: If RS232 is selected as the output mode, the analogue output will not be available for use by remote displays and data loggers etc.

The sensor must be set to RS232 mode if you wish to use the sensor in conjunction with a 7SDI-1000 SDI12 Converter.

3.2.6 Averaging number

This sets the level of averaging. Lower levels of averaging will decrease response times but may also increase the level of noise. The factory default is 120 which give a response time of approximately 1 second.

3.2.7 Advanced Settings

The Advanced Sensor Configuration screen allows the user to modify parameters such as Local Gravity, Specific Gravity and customized engineering units; it also lets the user to re-calibrate the pressure sensor using single point or two-point calibration.

Advanced sensor configuration - Analog mode

Local Gravity Enter a value between 9.5 and 10.5

Use Full Density Polynomial (t = temperature in deg C)

Specific Gravity Enter a value between 0.5 and 1.5

Water Density = t⁴ + t³ + t² + t +

Pressure		Temperature	
Eng. Unit	<input type="text" value="m H2O"/>	Eng. Unit	<input type="text" value="deg C"/>
Eng. Unit Gain	<input type="text" value="1.0"/>	Eng. Unit Gain	<input type="text" value="1.000000"/>
Eng. Unit Offset	<input type="text" value="0.0"/>	Eng. Unit Offset	<input type="text" value="0.000000"/>
User Cal. Gain	<input type="text" value="1.000000"/>	User Cal. Gain	<input type="text" value="1.000000"/>
User Cal. Offset	<input type="text" value="0.000000"/>	User Cal. Offset	<input type="text" value="0.000000"/>

Reset all Reset all

3.2.8 Local Gravity

Enter a new value directly into the text field.

3.2.9 Specific Gravity

There are two alternatives in specifying a value:

Where no temperature compensation is required, deselect Use Full Density Polynomial and enter a fixed value to the Specific Gravity field. The user can specify the coefficients of a fourth-order density polynomial for temperature compensation. To do this, select Use Full Density Polynomial and enter the desired coefficients in the corresponding fields; The Specific Gravity field will be greyed out and changed to value of 1.

3.2.10 Engineering Units

The interface also lets the user enter customized engineering units, together with offset and gain for both pressure and temperature readings; note that these unit settings only affect digital outputs displayed on the main screen.

Use Reset All to return to unity gain, zero offset, meters of water and degrees Celsius.

3.2.11 Calibrate Sensor

Use this button to re-calibrate the pressure sensor and follow the on-screen instructions to step through the required process. To perform a single-point calibration, select 'NO' when prompted to proceed with the next calibration point. Select 'YES' otherwise to complete the two-point calibration.

The user may need to repeat the calibration procedure to fine tune the offset and gain factors when large changes are made.

NOTES: All changes made to the Advanced Configuration screen, including data obtained from re-calibrating the sensor; do not take effect until the 'OK' button is clicked.

3.2.12 Pressure and Temperature Sensor Readings

The bottom section of the screen displays current readings for both pressure and temperature; this is only visible when RS232 is selected as sensor output.

3.2.13 Load Configuration

For loading a configuration file stored on PC to the sensor. This button is enabled as soon as a valid serial number is received. The interface will first check for a serial number match before proceeding to data transfer and resetting the sensor.

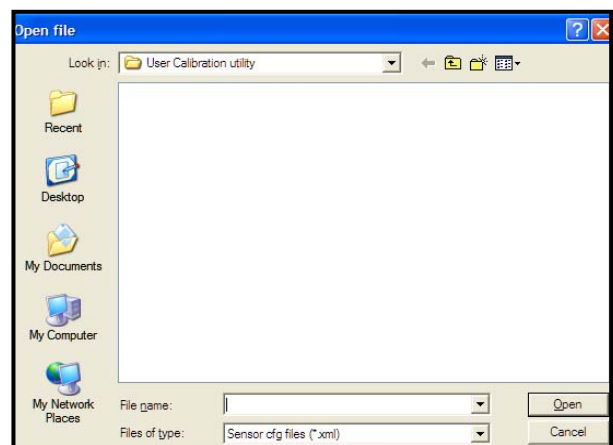

3.2.14 Save Configuration

Use this button to save the current sensor settings to a PC file. This button is enabled only after connection to a sensor has been established.

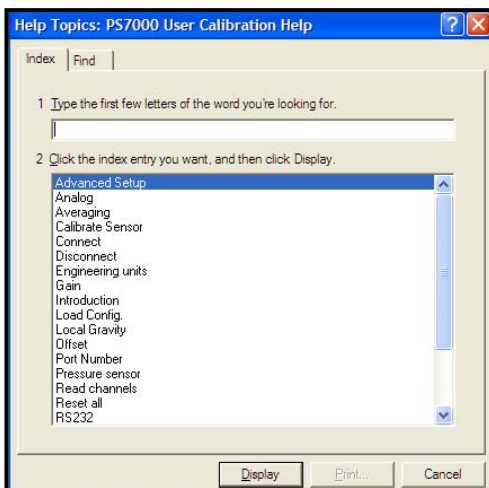
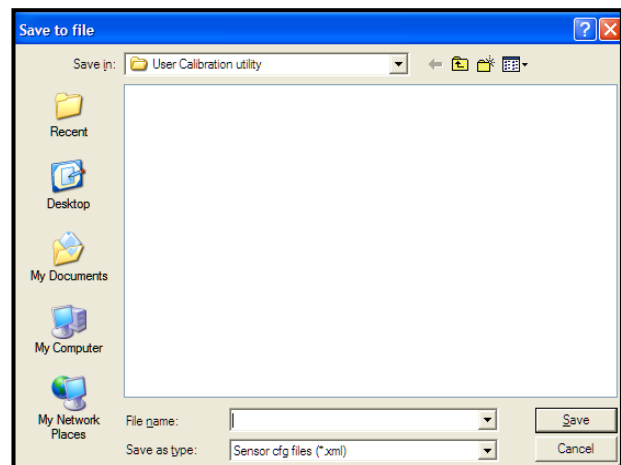

Fully Documented Help Function is available for PS7000 Utility by clicking the Help button or hitting the F1 key

3.3 Installation

3.3.1 Typical Sensor Installations

1. Edge of river/stream/lake embankment.
2. Side of boat/vessel.
3. Mounted within a stilling well off stream from main flow.
4. Mounted within drainage channels/pipes.
5. Suspended from dam walls or floating pontoon.
6. Sensor anchored to bed of lake/stream.

3.3.2 Field Installation must ensure:

- The sensor is anchored or held in position or located so it is not subject to any movement during normal operations.
- Sensor is protected from direct sunlight to avoid high temperature fluctuations
- Sensor is protected against high turbulence and possible debris loading during flow events

3.3.3 Cabling Considerations

Care should be taken with installation and field servicing to ensure the cable is not subjected to persistent pulling snagging or severe compression. Cyclic loading of the cable should also be avoided through careful sensor deployment. Additional stilling wells or mounting brackets may be required to prevent sensor movement which may cause long term cable movement. Where cable runs are required which may be subject to environmental effects (heat, water movement, sunlight, flood debris etc) it is advisable to protect the sensor cable inside a slightly larger diameter conduit such as PVC, steel or polyethylene. This also allows the sensor cable to be pulled out – should a sensor change-over be required at the site. Maximum cable runs up to several hundred meters are possible without affecting electrical signals. The maximum cable length is dependant on the capability of the com port of the computer. Most computers should be capable of driving a 150 to 200m cable length.

3.3.4 Typical Sensor Installations

1. Edge of river/stream/lake embankment.
2. Side of boat/vessel.
3. Mounted within a stilling well off stream from main flow.
4. Mounted within drainage channels/pipes.
5. Suspended from dam walls or floating pontoon.
6. Sensor anchored to bed of lake/stream.

3.3.5 Other Considerations

Environmental compatibility should be checked before using the sensors and advice sought from Greenspan if any doubt exists. The sensor utilises some 316 stainless components that are suitable in a majority of situations but care should be taken against possible corrosion in high Chloride, Sulphate or Ferric solutions. The body should always be totally immersed under the water to ensure that the sensor is at water temperature and to also avoid any possible anodic/cathodic action taking place on the components at the water-air interface. If using clamps to mount the sensor – these should be of a type that evenly clamps the sensor body without excessive loading that could damage the sensor body.

3.3.6 Guidelines for cleaning equipment

The sensor may be cleaned using a soft cloth, mild detergents and warm water. If the sensor shows signs of marine growth a light biocide can be used to clean and kill any biological growth on the sensor.

4 Appendix A -Additional Information

4.1 Specifications

Measurement Technique	1/2" ceramic capacitance transducer
Standard ranges available	Gauge 2.5, 5, 10 20 40 75 100m
	Absolute 20, 40, 75, 100m
Other Ranges Available	Yes (consult sales office)
Sensor Output	4-20mA, or optional 0-2.5Vdc, SDI12 (via 7SDI-1000)
Overall Accuracy (combined linearity, hysteresis and repeatability)	+/- 0.1% full scale
Temperature Accuracy	+/- 0.2°C
Long term stability	0.2% full scale per annum
Zero Offset and full scale maximum variation	+/- 0.02mA
Cable type	Polyurethane sheathed cable, OD 8mm, with 3mm vent tube, moulded entry, bare wire connection
Cable Lengths	10, 20, 30, 50, 100, 150m (32, 65, 100, 165, 325, 490 FT)
Closed Vent System (CVS)	Gauge sensors must be fitted with a CVS
Power Supply	8-30Vdc (at sensor) loop powered
Reverse Polarity Protected	Yes
Surge Current Protected	To 2kV
Warm Up Time to Stable Reading	<150ms
Current Consumption	Up to 20mA while turned on, 0mA when off
Operating Temperature	0-50°C
Storage Temperature	-5°C - +60°C
Max over pressure	At least twice the full scale range
Dimensions	315mm 47mm (12.6" x 1.78")
Weight	550g plus cable weight (665g per 10m length)
Wetted Materials	Ceramic, 316 passivated stainless steel, polyurethane, viton
CVS Dimensions: length x width x height	16cm x 7cm x 5cm

4.2 Quick Start Guide – PS1000 Pressure Sensor 4-20mA Output

Procedures for connecting and configuring the Greenspan PS1000 Sensor.
Further details in the Sensor Manual included on the Greenspan CD.

You should have received:

- Certificate of Conformance Sheet
- CD Manuals & Software
- Greenspan PS1000 Sensor
- Cable Options per order

Wiring for 4-20mA Output Sensor

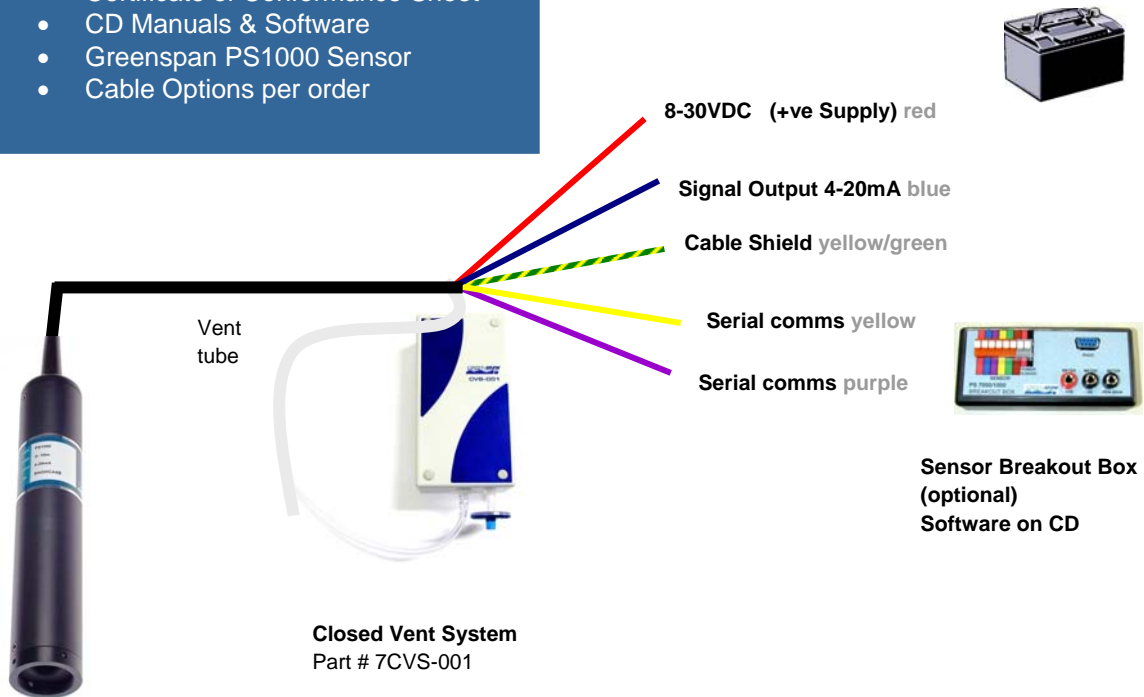

Sensor may be fitted with optional removable cable

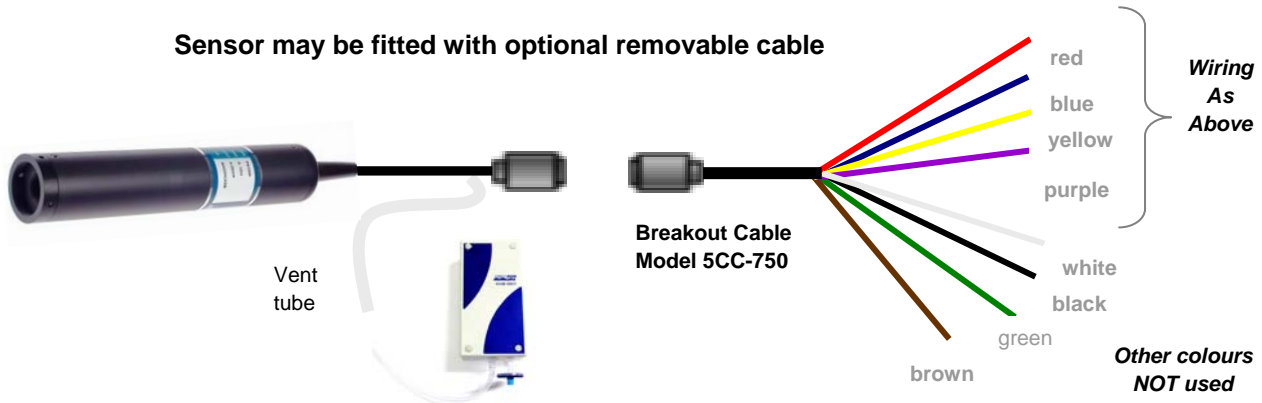

PS1000 provides a calibrated analogue output –4-20mA over the Sensor Full Scale range. (eg 0-10m.)
Sensor requires a nominal 12V DC power supply, but will operate from 8-30V DC.
Sensor output can be re ranged or the calibration adjusted using the Sensor Breakout Box and supplied software.
(Refer Breakout Box Quick Start Guide & Manual)

4.3 Quick Start Guide – PS1000 Pressure Sensor Voltage Output

Procedures for connecting and configuring the Greenspan PS1000 Sensor. Further details in the Sensor Manual included on the Greenspan CD.

You should have received:

- Certificate of Conformance Sheet
- CD Manuals & Software
- Greenspan PS1000 Sensor
- Cable Options per order

Wiring for Voltage Output Sensor

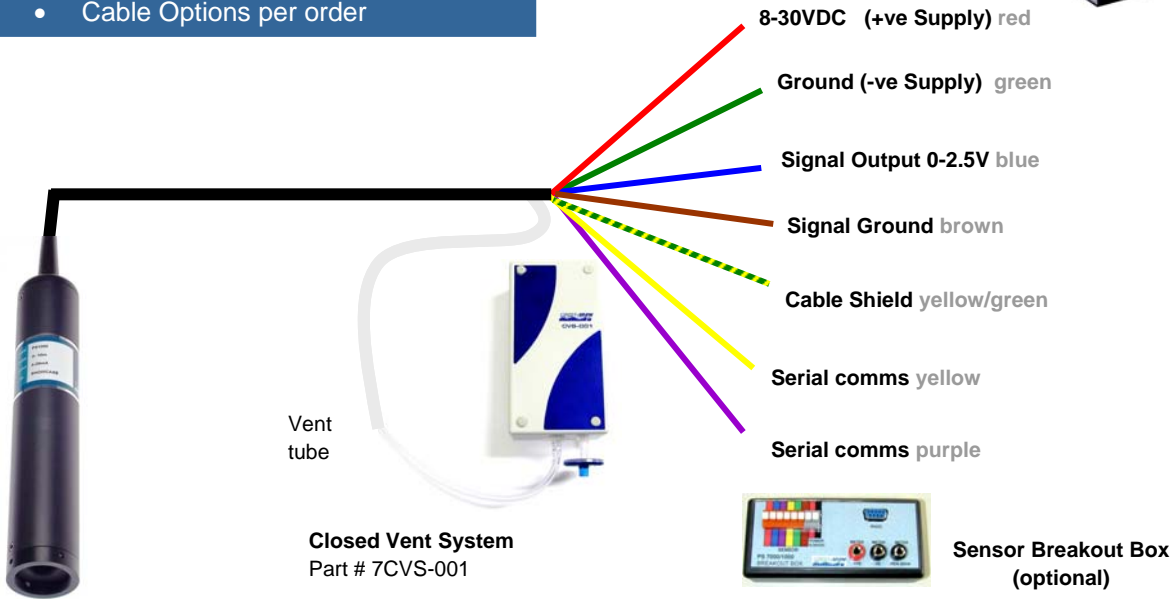

Sensor may be fitted with optional removable cable

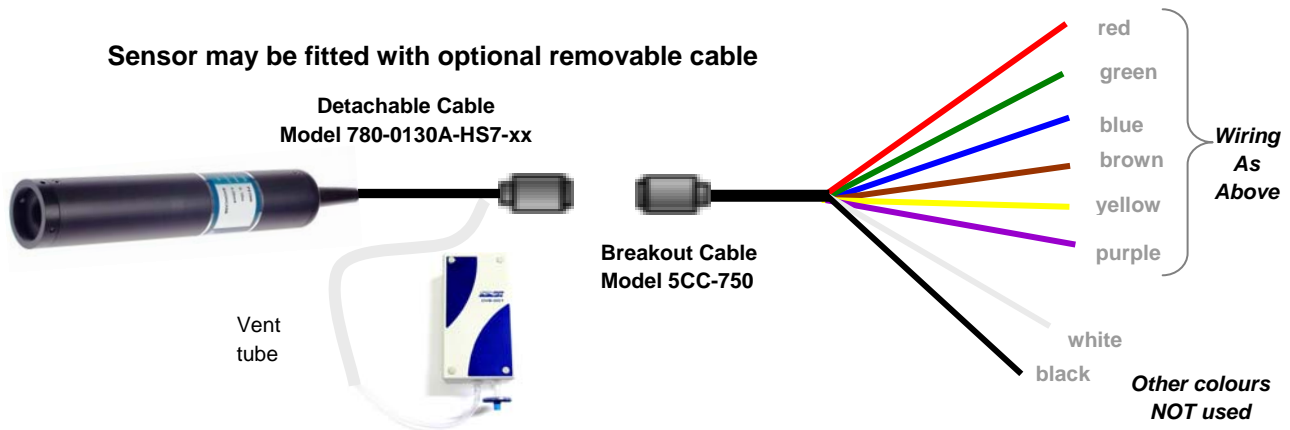

PS1000 provides a calibrated analogue output –0-2.5V (factory set) over the Sensor Full Scale range. (eg 0-10m.)

Sensor requires a nominal 12V DC power supply, but will operate from 8-30V DC. Sensor output can be re ranged or the calibration adjusted using the Sensor Breakout Box and supplied software. (Refer Breakout Box Quick Start Guide & Manual)

4.4 Example Certificate of Conformance



PS1000 Pressure Sensor

CERTIFICATE of CONFORMANCE

Customer: "Click here & type Customer name"
Model No. PS1000 Pressure Sensor (Tyco Environmental Systems material # 700-7000)
Sales Order Reference: "Click here & type SO Reference"
Serial Number: "Click here & type S/N"

Product Information



PS1000 Pressure Sensor

Range	"Type Range here" H ₂ O	
Output	Current	FS 20.00mA
		Zero 4.00mA
	Serial	RS232
Accuracy	+/- 0.1% FS (over 0-50°C) *	
Sensor Type	Gauge/Absolute (delete applicable)	
Cable Length	"Click here & type Cable length" M	
Supply Voltage	8 - 30 VDC	
Connection	+ve	Red
	Signal Output	Blue
	Cable Shield	Green/Yellow
	Serial	Yellow & purple
Connection Code	BW4 or Detachable (delete applicable)	
*Combined temperature and repeatability		

User Notes

1. Australian Standard, AS1376 is used to convert kPa to metres of water (1kPa = 102.15 mm water) at 20°C
2. Dismantling of the sensor will void the warranty. Contact your agent for technical advice.
3. The sensor is protected against reverse polarity connection.
4. The sensor is fitted with a lightning protector/surge device.
5. The sensor is compensated for temperature induced errors over the range 0 -50°C.
6. All sensors include a ¼ " tapered BSP thread for external fitting.
7. Warm up time to stable reading is 0.15 seconds. Full accuracy at 1 second.

Inspected By: _____ 1st January 2009

Manufactured By:
 Tyco Environmental Systems (Greenspan Analytical Plant)
 22 Palmerin Street
 WARWICK QLD 4370
 AUSTRALIA Phone: + 61 (0)7 46601888

4.5 Engineering Note – Detachable Cables

ENGINEERING NOTE

RELEASE DATE: 28/4/2008

SUBJECT: Connecting and Disconnecting the Detachable Cable for Greenspan Sensors (packaged in 47mm & 65mm Tubes)

IMPORTANT NOTE:

You have been supplied with:

2 x O-Rings (Greenspan part number 011-OR16X2.5)

2 x Grub Screws (Greenspan part number 512-M4X6SS316P)

1 x Allen Key

Prior to connecting your sensors to the detachable cable, please ensure that the detachable cable entry has been fitted with O-Rings supplied as detailed above. Ensure O-Ring grooves are greased and then slide O-Rings and fit into the recessed grooves.



Refer to the following instructions for **connecting** to your sensor to the detachable cable

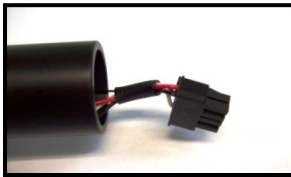

1. The sensor connector is exposed and ready to connect to the cable connector.

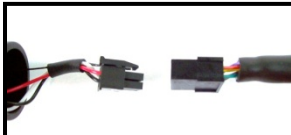

2. Align the cable connector with the sensor connector and push together. The connector is polarized and will only fit together one way.

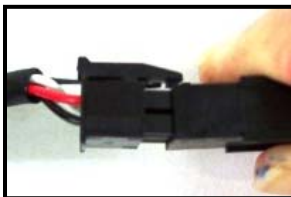

3. Once connectors are completely pushed together, the rocker arm on the sensor connector will clip in with the cable connector and secure the connection.



4. Carefully feed the connection back into the sensor tube taking caution not to crimp or damage any wiring. Ensure the O-Rings have been fitted to the moulded cable entry as directed at the beginning of this document



5. Twist carefully to align the grub screw holes. Firmly push the tube back onto the moulded cable entry



7. Screw in two (2) 512-M4X6SS316P grub screws to secure the cable and the sensor with supplied Allen key



8. The cable is now securely fitted to the sensor.

Refer to the following instructions for **disconnecting** your sensor to the detachable cable



1. Sensor with cable attached and ready for cable disconnection.



2. Remove the two (2) grub screws (Greenspan part #512-M4X6SS316P) using the Allen key supplied. (N.B Allen key is supplied in spare parts kit with original packaging)

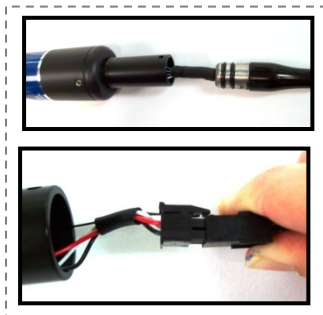

3. CAREFULLY pull tube away from cable mould. Once the tube has been pulled away from cable mould, the connector will be revealed as pictured left.

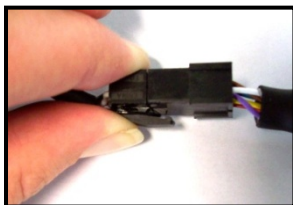

4. Release locking device on the connector by gently pinching rocker arm on the cable connector and pull apart.

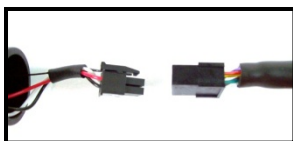

5. The sensor and cable are now detached.

Note: When the cable is not connected to a sensor, please ensure the supplied vent cap is fitted to the vent tube (if applicable)

4.6 Engineering Note – Closed Vent System

ENGINEERING NOTE

RELEASE DATE: 06th JUNE 2006

EDITION 1.6

SUBJECT: **CVS-001, Closed Venting System for Vented Sensors**

INTRODUCTION

When pressure sensors are deployed, there can be a difference between the atmospheric temperature and the temperature of the sensor at depth.

This temperature differential causes a pumping effect to occur whereby moist air from the surface is drawn into the sensor through the vent line. This moisture can condense on sensitive electronic components due to warm surface air cooling inside the sensor.

Sealing the system against exposure to the atmosphere and conditioning the existing air in the vent tube can alleviate this problem. Silica desiccant crystals easily absorb moisture thereby drying the air and are used in the closed loop venting system CVS-001.

The effectiveness of the closed venting method is compromised if the system is disassembled. Therefore, once installed or reassembled, some time is required for trapped air to become dry again. One advantage of this method is that the volume of air being dried is always constant therefore the desiccant crystal will not become saturated.

INSTALLATION

Suggested Installation Only

The unit is fitted with a DIN clip for fitting to standard DIN rail installations. Sensor cable wires are terminated in suitable DIN rail screw terminal blocks available from electrical suppliers. A vent tube joiner (supplied) is fitted between the CVS-001 and the cable vent line. See Figure 1.

A single CVS-001 is designed to handle sensor cable lengths up to **70 metres**. Multiple units may be joined together for greater capacity. For example, if a 140 metre cable is used, two units connected via a 'T-Piece' (available from Greenspan, Part, 071-9112) and extra joiner tubing (071-0008) are connected as per Figure 2.

Note that there are many ways of installing CVS-001, these are only suggestions.

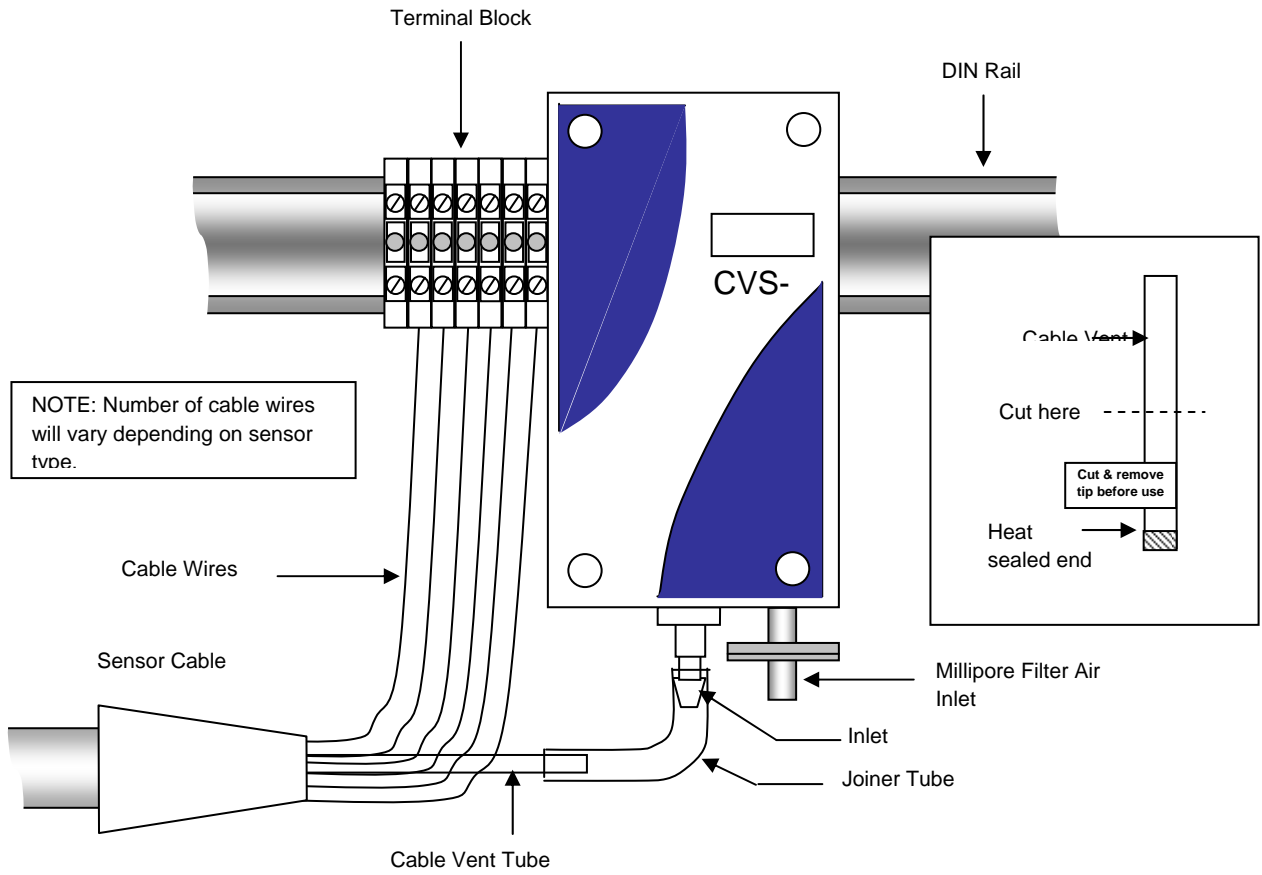

Figure 1. Single Installation, (Suggestion Only)

Remove the seal by cutting the end of the joiner tube with a sharp knife prior to connection. See inset, figure 1.

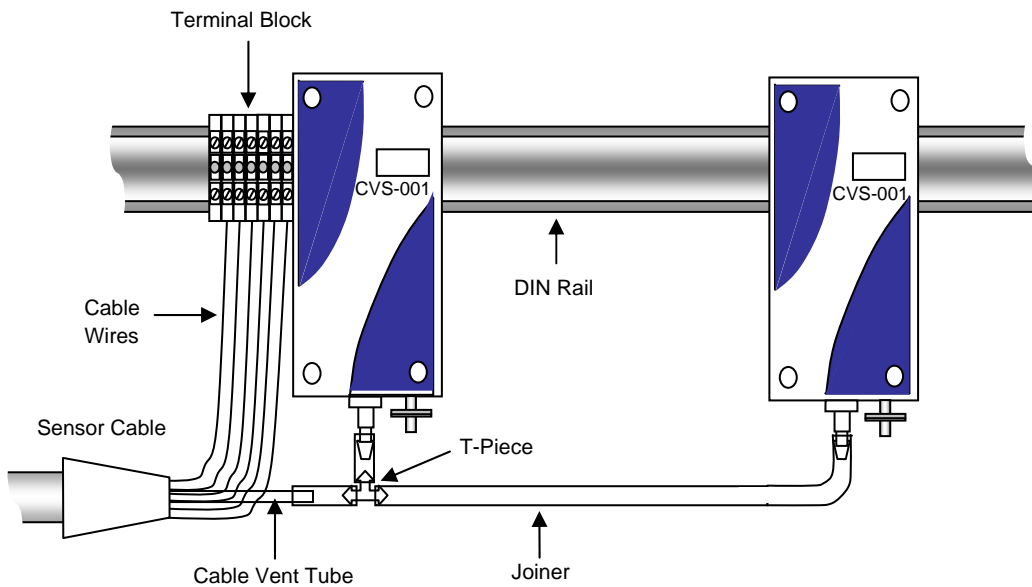

Figure 2. Multiple Units

SETUP FOR USE

For correct operation of the desiccant system it is necessary to partially inflate the breather bag inside the CVS-001 to enable it to expand and contract with atmospheric pressure changes.

1. Cut vent tube below tag. See Figure 1.
2. Attach 60ml syringe to joiner tube and withdraw all air from breather bag.
3. Remove syringe, recharge, and apply 60ml, remove syringe, recharge and repeat for a further 60ml (total 120ml = half of max. capacity of 240ml).
4. Connect joiner tube to cable vent tube.
5. If multiple units are being used the volume of air required for priming must increase by approximately 120ml for every unit connected.

Note: Only remove the inlet seal on the CVS-001 when ready to install the sensor vent tube. If dismantling the system ensure that the inlet is sealed.

CABLE BREAKOUT

For existing sensor cables where the vent tube is not accessible, a cable breakout kit (CBR-001) is available. This enables the vent tube to be separated from the wire cores and the junction sealed against moisture.

For cables with connectors already fitted, (HS7, CX18) it is necessary to cut the cable to remove the connector. **It is important to leave a length of cable attached to the connector to allow re-termination within CBR-001.** Good Engineering practice is recommended for all joins.

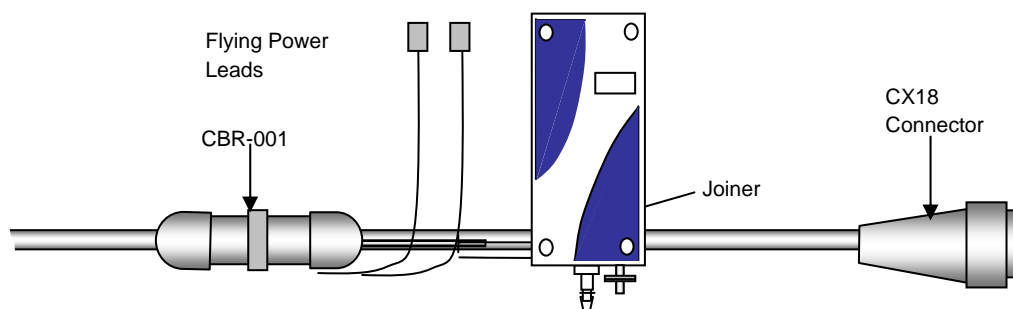

Figure 3. With Breakout CBR-001